

BAFFLES

RAPID PLUG AND UNPLUG SYSTEM (PATENTED SYSTEM)

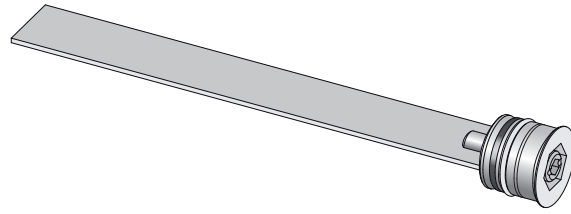

CODE: **RL-..F**

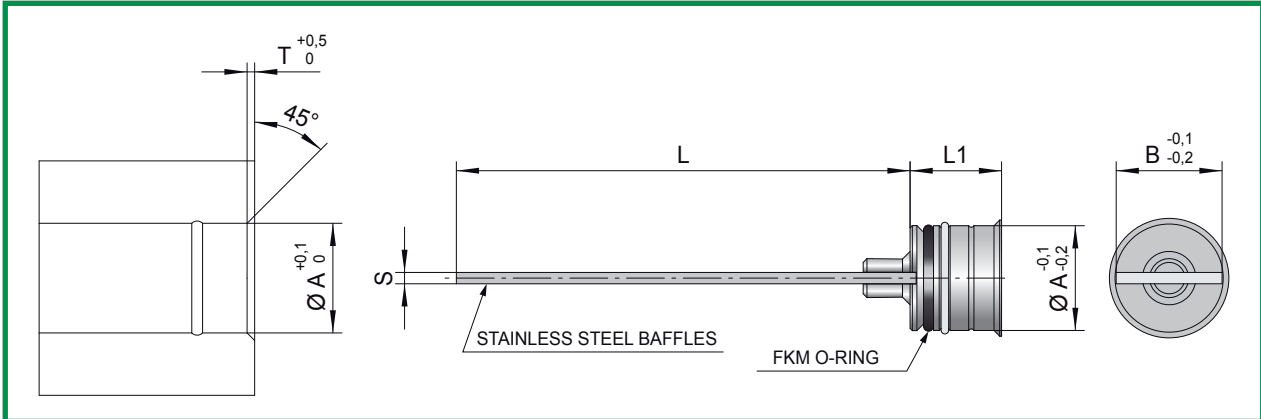

CODE	A	B	T	S	L1	L			
RL-6F	6	6	0,7	1	7,5	100	200	300	
RL-8F	8	8	1	1	9,5	100	200	300	
RL-10F	10	10	1	1	12,5	100	200	300	
RL-12F	12	12	1	1	12,5	100	200	300	
RL-14F	14	14	1	1	12,5	100	200	300	
RL-15F	15	15	1,2	1	14	150	300	450	600
RL-16F	16	15,5 16	1,2	1	14	150	300	450	600
RL-19F	19	19	1,2	1	14	150	300	450	600
RL-20F	20	19,5 20	1,2	1	14	150	300	450	600
RL-25F	25	24,5 25	1,2	1	14	150	300	450	600
RL-30F	30	30	1,2	1	14	150	300	450	600

Order example: RL-8Fx100

N.B.: The baffles RL-16F-20F-25F are available with two different baffle dimensions "B".

Order example:

RL-16Fx150P (baffle 15,5mm)

RL-16Fx150G (baffle 16mm)

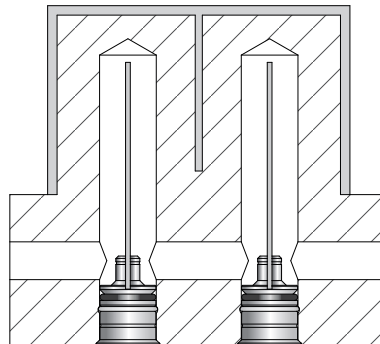

CHARACTERISTICS

- 1) RAPID MACHINING OF THE HOUSING;
- 2) RAPID FITTING AND REMOVING;
- 3) SECURE SEAL IS MAINTAINED EVEN UNDER HIGH PRESSURE CONDITIONS (~100 BAR).

SET 'F'

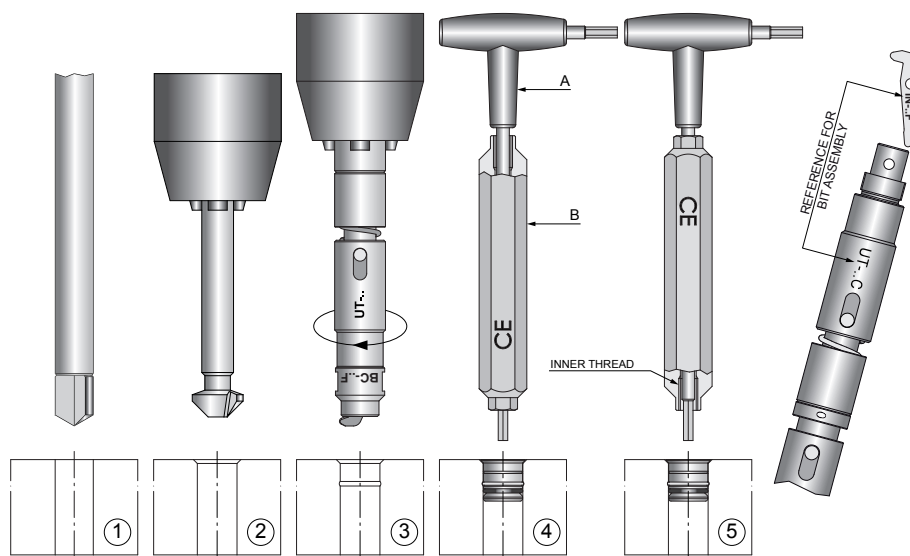

EXECUTION PLUGS' HOUSING

1. PERFORM THE HOLE WITH GUN DRILL (the diameter of the drill has to correspond to the mark of the plug; for example: for the plug type TR-8F use drill $\varnothing 8$. See picture 1)
2. PERFORM CHAMFERING. See picture 2
3. PERFORM RETAINING GROOVE WITH SUITABLE TOOL. See picture 3

SOME ADVICE FOR THE CORRECT USE OF ABOVE MENTIONED TOOL

- A. Before beginning the operation put a drop of oil on the piece by the chamfer (picture 2) to encourage the sliding of the centering bush of the tool.
- B. The descent in vertical of the tool has to be slow (as adopted when a center drill is used). Consider however that such a tool works only in the last millimeter of the descent.
- C. When the two elements of the tool separated by the spring (visible) touch each other, the operation is completed. Now neither making further pressure on the tool nor stopping in such a position more than a few seconds is not advisable (so to avoid the heating of the centering bush that rubs on the piece).
- D. The above mentioned advice, related to the pressure that has to be applied on the tool, are obviously usable by the worker only in case of operation on a drill or also on a miller, only if provided by a mobile chuck (type drill) so to have the sensitivity of the practiced pressure. In case of performing the above mentioned operation on a machine with fixed head or on a machining center, it's necessary to use the tool with the pressure compensator (provided on request).

PLUGS ASSEMBLY

1. Insert the piece to be assembled in its seat.
2. Insert the key as in picture 4.
3. Holding the key "A" tight, rotate the key "B" clockwise blocking the plug with strong pressure, but using only the hands (without the help of any other keys to subsequently increase the pressure of locking).

PLUGS DISASSEMBLY

1. Insert the keys as in picture 4.
2. Unblock the plug holding the key "A" tight and rotating the key "B" counter clockwise (1-2 turns maximum).
3. Remove the keys.
4. Using the key "B" from the side with the inner thread hook the plug and extract.

POSITIONING OF THE BUBBLES

In order to obtain a proper circulation of the coolant, position the reference mark **S** that you can find on the bubble as indicated in the diagram.

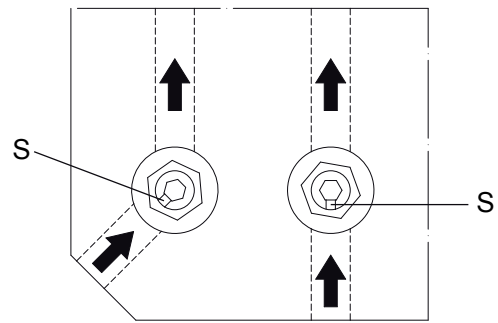

POSITIONING OF THE BAFFLES

In order to obtain a proper circulation of the liquid, position the reference marks **S** that you can find on the baffle as indicated in the diagram.

The fiducial marks correspond to the position of the blade.

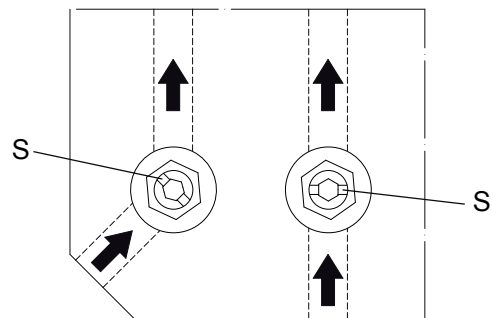

APPLICATION OF BAFFLES RL / RLS

Considering that the baffles with \varnothing bigger than 14mm are available only in the set F, and if it is not possible to machine the hole with gun drill, it is advisable to apply the baffle set F with a width B lower than the major diameter and to proceed as in the example.

EXEMPLE OF APPLICATION RL-16Fp (B=15,5mm)

1. perform hole with drill $\varnothing 15,5$;
2. perform blade with a reamer $\varnothing 16$ for a depth of $L2+5\text{mm}$;
3. to go on with the procedure for the application of the item set F.

SET KEYS FOR THE ASSEMBLY OF STANDARD SET AND SET F

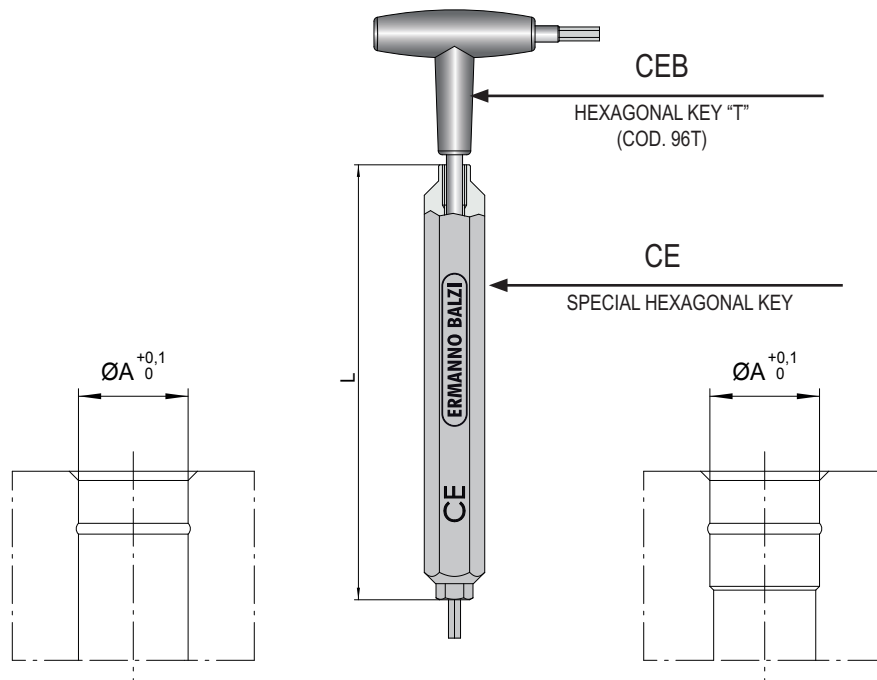

CODE	A	L
CE-4 CEB-1,5	$\varnothing 5$	60

CODE	A	L
CE-5 CEB-2	$\varnothing 6 / \varnothing 6,5$	97

CODE	A	L
CE-6,5 CEB-2,5	$\varnothing 8 / \varnothing 8,5$	108

CODE	A	L
CE-8 CEB-3	$\varnothing 10 / \varnothing 10,5$	108
	$\varnothing 12 / \varnothing 12,5$	
	$\varnothing 14 / \varnothing 14,5$	

CODE	A	L
CE-12 CEB-5	$\varnothing 15$	126
	$\varnothing 16$	
	$\varnothing 18$	
	$\varnothing 20$	
	$\varnothing 25$	
	$\varnothing 30$	

TOOLS FOR THE PERFORMING OF THE RETAINING GROOVE

SET "F"

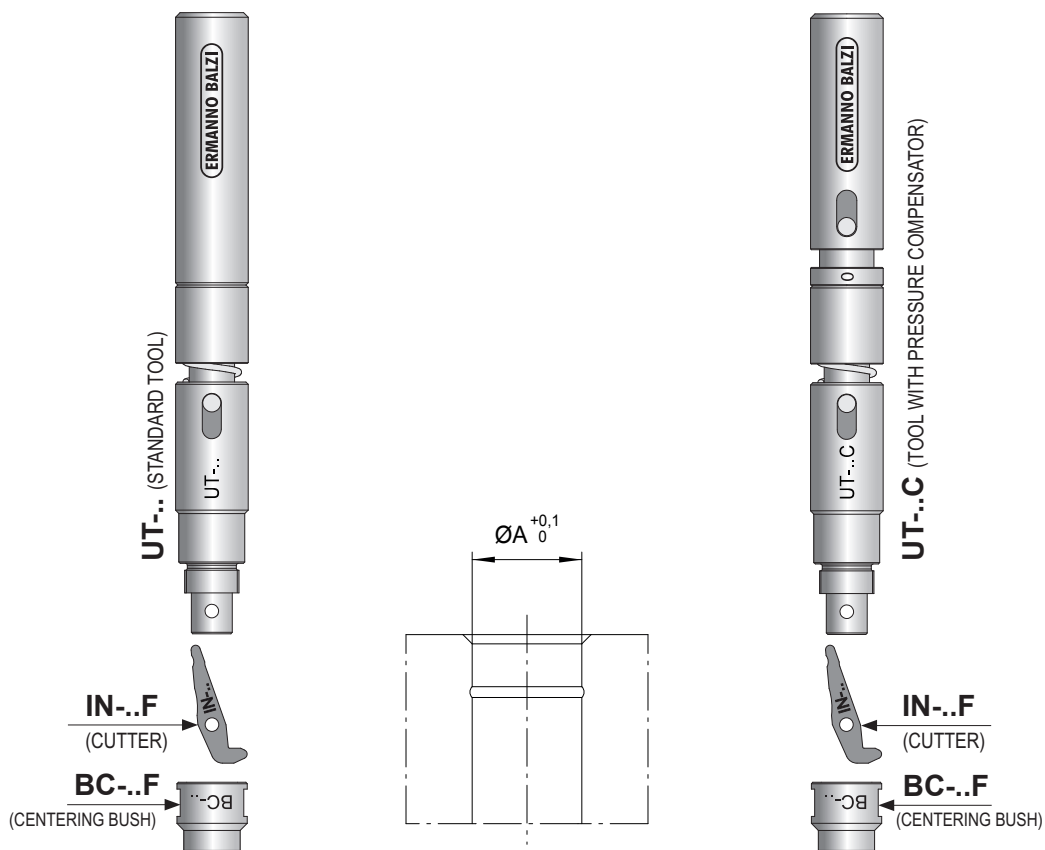

CODE	A	BC	IN
UT-0 / UT-0C	$\varnothing 5$	BC-5F	IN-5F

CODE	A	BC	IN
UT-1 / UT-1C	$\varnothing 6$	BC-6F	IN-6F

CODE	A	BC	IN
UT-2 / UT-2C	$\varnothing 8$	BC-8F	IN-8F

CODE	A	BC	IN
UT-3 / UT-3C	$\varnothing 10$	BC-10F	IN-10F
	$\varnothing 11$	BC-11F	IN-11F
	$\varnothing 11,5$	BC-11,5F	IN-11,5F
	$\varnothing 12$	BC-12F	IN-12F
	$\varnothing 14$	BC-14F	IN-14F
	$\varnothing 15$	BC-15F	IN-15F

CODE	A	BC	IN
UT-4 / UT-4C	$\varnothing 16$	BC-16F	IN-16F
	$\varnothing 18$	BC-18F	IN-18F
	$\varnothing 19$	BC-19F	IN-19F
	$\varnothing 20$	BC-20F	IN-20F
	$\varnothing 25$	BC-25F	IN-25F
	$\varnothing 30$	BC-30F	IN-30F

STANDARD CUTTER		
CODE	CUTTING SPEED m/min.	RPM
IN-5F	9,4÷11	600÷700
IN-6F	9,4÷11	500÷600
IN-6	9,4÷11	460÷550
IN-8F	9,4÷11	370÷450
IN-8	9,4÷11	350÷420
IN-10F	9,4÷11	300÷360
IN-10	9,4÷11	290÷340
IN-12F	9,4÷11	250÷300
IN-12	9,4÷11	240÷290
IN-14F	9,4÷11	215÷260
IN-14	9,4÷11	210÷250
IN-15F	9,4÷11	200÷240
IN-16F	9,4÷11	190÷225
IN-18F	9,4÷11	200÷170
IN-19F	9,4÷11	190÷160
IN-20F	9,4÷11	150÷180
IN-25F	9,4÷11	120÷140
IN-30F	9,4÷11	100÷120

CARBIDE CUTTER		
CODE	CUTTING SPEED m/min.	RPM
IN-5FD	19÷23	1200÷1400
IN-6FD	19÷23	1000÷1200
IN-6D	19÷23	920÷1100
IN-8FD	19÷23	750÷900
IN-8D	19÷23	700÷850
IN-10FD	19÷23	600÷720
IN-10D	19÷23	570÷680
IN-12FD	19÷23	500÷600
IN-12D	19÷23	480÷580
IN-14FD	19÷23	430÷520
IN-14D	19÷23	420÷500
IN-16FD	19÷23	380÷450
IN-18FD	19÷23	340÷400
IN-20FD	19÷23	300÷360
IN-25FD	19÷23	240÷290

MATERIALS HARDNESS

The standard cutters code IN-.. are made in HSS and titanium carbonitride coated. Such cutters can machine steel with maximum hardness of 40÷42 HRC; it is necessary to consider that as the hardness of the steel increases the working life of the cutter becomes significantly shorter. In order to meet the growing need to assembly cooling components on pre hardened inserts, a new set of cutters made in carbide steel code IN-..D able to machine steel with hardness up to 50÷52 HRC, is now available.

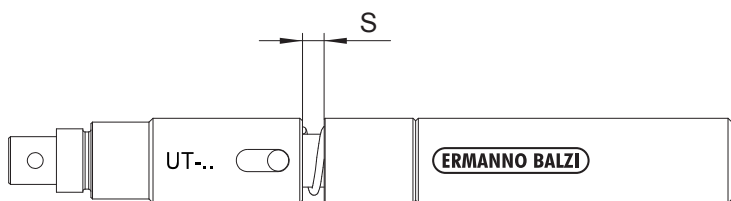

TOOL	S
UT-0	4,3
UT-1	4,3
UT-2	4,3
UT-3	4,7
UT-4	5,1

ADVICES FOR THE CORRECT USE OF THE TOOL "UT"

1. The tool "UT" is designed to be used on machines where the forward movement is manually controlled.
2. The cutter starts the machining of the groove a few millimeters after the centering bush "BC" get in contact with the chamfer on the hole. Starting from this point the forward movement has to be slow.
3. The machining of the groove is completed when the gap "S" is completely closed by the forward movement of the tool.
4. Once the forward movement is completed neither making further pressure on the tool, nor stopping in such a position more than a few seconds is advisable.

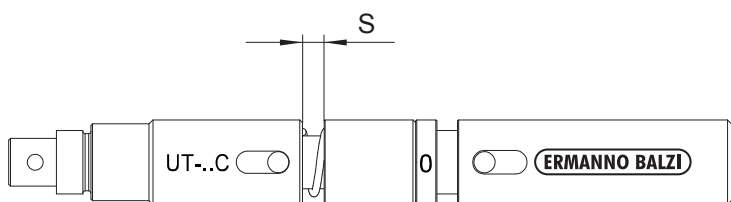

TOOL	S ^{+2 / +3}
UT-0C	4,3
UT-1C	4,3
UT-2C	4,3
UT-3C	4,7
UT-4C	5,1

ADVICES FOR THE CORRECT USE OF THE TOOL "UT-C"

1. The tool "UT-C" is designed to be used on CNC machines where forward movement is electronically controlled.
2. It is possible to move in fast forward till 2 mm from the working position (contact point between centering bush "BC" and chamfer of the hole).
3. Starting from this point a feed rate of 0,05 mm/rotation is suggested.
4. The machining of the groove is completed when the gap "S" is completely closed by the forward movement of the tool. To guarantee the proper machining we suggest to set an extra stroke of 2+3 mm, the extra stroke will be compensated by a spring inside the tool.
5. Once the forward movement is completed neither making further pressure on the tool, nor stopping in such a position more than a few seconds is advisable.

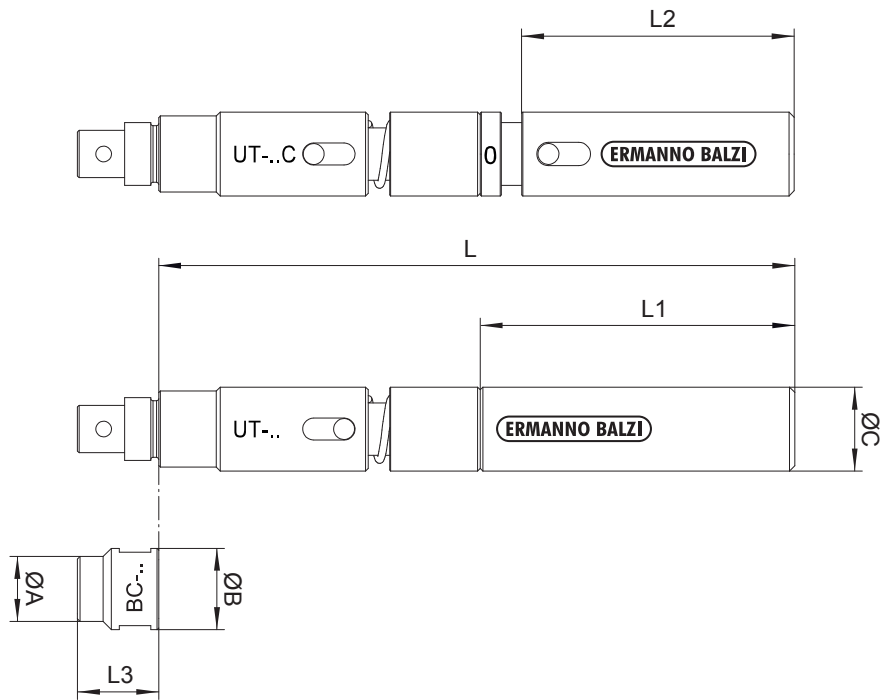

CODE	C	L	L1	L2
UT-0 / UT-0C	10	110	70	62
UT-1 / UT-1C	10	110	70	62
UT-2 / UT-2C	12	108	60	52
UT-3 / UT-3C	16	122	60	54

UT-0 / UT-0C			
CENTERING BUSH	A	B	L3
BC-5F	5	10	12

UT-1 / UT-1C			
CENTERING BUSH	A	B	L3
BC-6F	6	10	12
BC-6	6,5	10	12

UT-2 / UT-2C			
CENTERING BUSH	A	B	L3
BC-8F	8	12	14,5
BC-8	8,5	12	14,5

UT-3 / UT-3C			
CENTERING BUSH	A	B	L3
BC-10F	10	14,5	15,5
BC-10	10,5	14,5	15,5
BC-11F	11	15,5	15,5
BC-11,5F	11,5	15,5	15,5
BC-12F	12	15,5	15,5
BC-12	12,5	15,5	15,5
BC-14F	14	16,5	15,5
BC-14	14,5	16,5	15,5
BC-15F	15	17,5	15,5

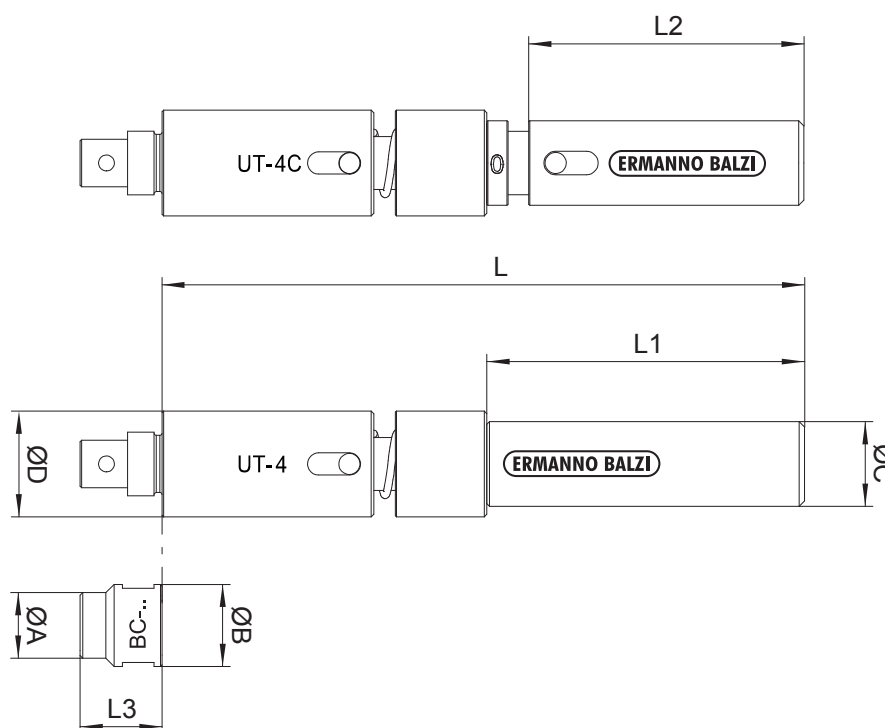

CODE	C	D	L	L1	L2
UT-4 / UT-4C	16	20	122	60	54

UT-4 / UT-4C			
CENTERING BUSH	A	B	L3
BC-16F	16	19,5	15,5
BC-18F	18	21	15,5
BC-19F	19	22	15,5
BC-20F	20	23	15,5
BC-25F	25	28	15,5
BC-30F	30	34	15,5

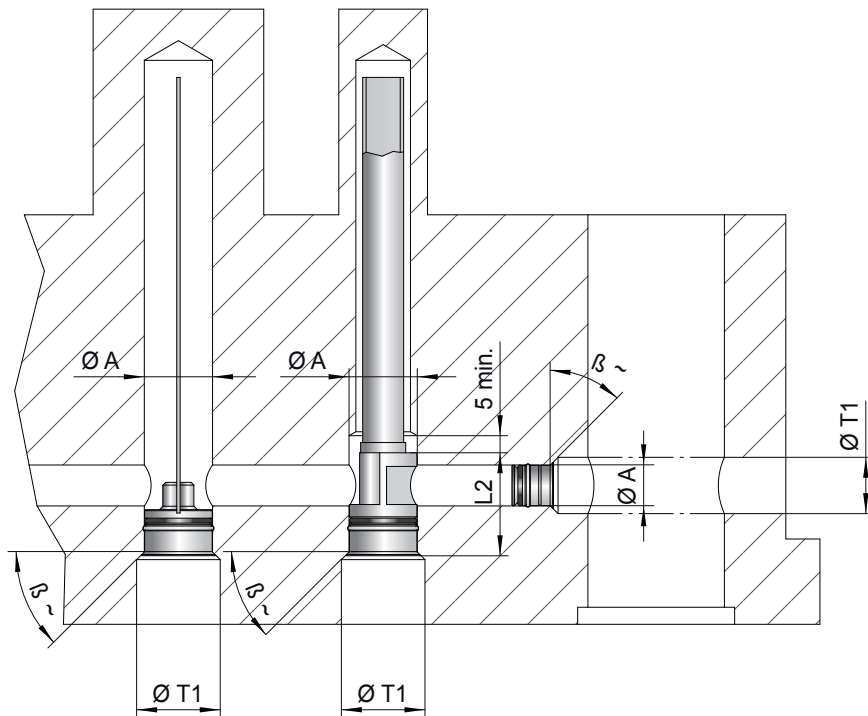

NOTE:

1. In the case where it is necessary to position some cooling elements in depth (as in the diagram above) and it is desired to execute the retaining groove using the appropriate tool, you will have to machine the undercut ØT1 with the measures indicated in table.
2. The angle β (front inclination of the drill) should vary from a minimum of 0° to a maximum of 45° .
3. During the execution of a seat with double diameter (as in the diagram above), the depth of the ØA must be at least 5mm longer than the dimension «L2» of the bubbles.

DIMENSION ØA OF THE ITEM TO APPLY	ØT1	L2
5	10,5	/
6 / 6,5	10,5	/
8 / 8,5	13	18
10 / 10,5	16,5	22,5
11	16,5	/
11,5	16,5	/
12 / 12,5	16,5	24
14/14,5	17,5	24,5
15	20	/
16	20,5	27,5
18	22,5	/
19	23,5	/
20	24,5	29,5
25	29	33,5
30	35	/

"F" SERIES TOOL BOX

TOOL WITHOUT PRESSURE COMPENSATION SYSTEM



CODE	F SERIES SET COMPOSITION
UT	N°1 SINGLE TOOL
CE	N°1 SPECIAL HEXAGONAL KEY
CEB	N°1 "T" BETA HEXAGONAL KEY
BC-F	N°1 CENTERING BUSH FOR EACH SIZE
IN-F	N°1 CUTTER FOR EACH SIZE

Order example: CSF-10

CODE	CSF-5	CSF-6	CSF-8	CSF-10	CSF-11	CSF-11,5	CSF-12	CSF-14	CSF-15
UT-0	✓								
UT-1		✓							
UT-2			✓						
UT-3				✓	✓	✓	✓	✓	✓
BC-5F	✓								
BC-6F		✓							
BC-8F			✓						
BC-10F				✓					
BC-11F					✓				
BC-11,5F						✓			
BC-12F							✓		
BC-14F								✓	
BC-15F									✓
IN-5F	✓								
IN-6F		✓							
IN-8F			✓						
IN-10F				✓					
IN-11F					✓				
IN-11,5F						✓			
IN-12F							✓		
IN-14F								✓	
IN-15F									✓
CE-4	✓								
CE-5		✓							
CE-6,5			✓						
CE-8				✓	✓	✓	✓	✓	
CE-12									✓
CEB-1,5	✓								
CEB-2		✓							
CEB-2,5			✓						
CEB-3				✓	✓	✓	✓	✓	
CEB-5									✓

TOOL WITHOUT PRESSURE COMPENSATION SYSTEM

CODE	F SERIES SET COMPOSITION
UT	N°1 SINGLE TOOL
CE	N°1 SPECIAL HEXAGONAL KEY
CEB	N°1 "T" BETA HEXAGONAL KEY
BC-F	N°1 CENTERING BUSH FOR EACH SIZE
IN-F	N°1 CUTTER FOR EACH SIZE



Order example: CSF-16

CODE	CSF-16	CSF-18	CSF-19	CSF-20	CSF-25	CSF-30
UT-4	✓	✓	✓	✓	✓	✓
BC-16F	✓					
BC-18F		✓				
BC-19F			✓			
BC-20F				✓		
BC-25F					✓	
BC-30F						✓
IN-16F	✓					
IN-18F		✓				
IN-19F			✓			
IN-20F				✓		
IN-25F					✓	
IN-30F						✓
CE-12	✓	✓	✓	✓	✓	✓
CEB-5	✓	✓	✓	✓	✓	✓

"F" SERIES TOOL BOX

TOOL WITHOUT PRESSURE COMPENSATION SYSTEM



CODE	F SERIES SET COMPOSITION
UT	N°1 SINGLE TOOL
CE	N°1 SPECIAL HEXAGONAL KEY
CEB	N°1 "T" BETA HEXAGONAL KEY
BC-F	N°1 CENTERING BUSH FOR EACH SIZE
IN-F	N°1 CUTTER FOR EACH SIZE

Order example: CSF-10-12

CODE	CSF-10-11	CSF-10-11,5	CSF-10-12	CSF-10-14	CSF-11-11,5	CSF-11-12	CSF-11-14	CSF-11,5-12	CSF-11,5-14	CSF-12-14
UT-3	✓	✓	✓	✓	✓	✓	✓	✓	✓	✓
BC-10F	✓	✓	✓	✓						
BC-11F	✓				✓	✓	✓			
BC-11,5F		✓			✓			✓	✓	
BC-12F			✓			✓		✓		✓
BC-14F				✓			✓		✓	✓
IN-10F	✓	✓	✓	✓						
IN-11F	✓				✓	✓	✓			
IN-11,5F		✓			✓			✓	✓	
IN-12F			✓			✓		✓		✓
IN-14F				✓			✓		✓	✓
CE-8	✓	✓	✓	✓	✓	✓	✓	✓	✓	✓
CEB-3	✓	✓	✓	✓	✓	✓	✓	✓	✓	✓

"F" SERIES TOOL BOX

TOOL WITHOUT PRESSURE COMPENSATION SYSTEM

CODE	F SERIES SET COMPOSITION
UT	N°1 SINGLE TOOL
CE	N°1 SPECIAL HEXAGONAL KEY
CEB	N°1 "T" BETA HEXAGONAL KEY
BC-F	N°1 CENTERING BUSH FOR EACH SIZE
IN-F	N°1 CUTTER FOR EACH SIZE



Order example: CSF-10-12

CODE	CSF-10-12-14	CSF-16-20	CSF-16-25	CSF-20-25	CSF-16-20-25
UT-3	✓				
UT-4		✓	✓	✓	✓
BC-10F	✓				
BC-12F	✓				
BC-14F	✓				
BC-16F		✓	✓		✓
BC-20F		✓		✓	✓
BC-25F			✓	✓	✓
IN-10F	✓				
IN-12F	✓				
IN-14F	✓				
IN-16F		✓	✓		✓
IN-20F		✓		✓	✓
IN-25F			✓	✓	✓
CE-8	✓				
CE-12		✓	✓	✓	✓
CEB-3	✓				
CEB-5		✓	✓	✓	✓

"F" SERIES TOOL BOX

TOOL WITH PRESSURE COMPENSATION SYSTEM



CODE	F SERIES SET COMPOSITION
UT-C	N°1 SINGLE TOOL
CE	N°1 SPECIAL HEXAGONAL KEY
CEB	N°1 "T" BETA HEXAGONAL KEY
BC-F	N°1 CENTERING BUSH FOR EACH SIZE
IN-F	N°1 CUTTER FOR EACH SIZE

Order example: CSF-10C

CODE	CSF-5C	CSF-6C	CSF-8C	CSF-10C	CSF-11C	CSF-11,5C	CSF-12C	CSF-14C	CSF-15C
UT-0C	✓								
UT-1C		✓							
UT-2C			✓						
UT-3C				✓	✓	✓	✓	✓	✓
BC-5F	✓								
BC-6F		✓							
BC-8F			✓						
BC-10F				✓					
BC-11F					✓				
BC-11,5F						✓			
BC-12F							✓		
BC-14F								✓	
BC-15F									✓
IN-5F	✓								
IN-6F		✓							
IN-8F			✓						
IN-10F				✓					
IN-11F					✓				
IN-11,5F						✓			
IN-12F							✓		
IN-14F								✓	
IN-15F									✓
CE-4	✓								
CE-5		✓							
CE-6,5			✓						
CE-8				✓	✓	✓	✓	✓	
CE-12									✓
CEB-1,5	✓								
CEB-2		✓							
CEB-2,5			✓						
CEB-3				✓	✓	✓	✓	✓	
CEB-5									✓

TOOL WITH PRESSURE COMPENSATION SYSTEM

CODE	F SERIES SET COMPOSITION
UT-C	N°1 SINGLE TOOL
CE	N°1 SPECIAL HEXAGONAL KEY
CEB	N°1 "T" BETA HEXAGONAL KEY
BC-F	N°1 CENTERING BUSH FOR EACH SIZE
IN-F	N°1 CUTTER FOR EACH SIZE

Order example: CSF-16C



CODE	CSF-16C	CSF-18C	CSF-19C	CSF-20C	CSF-25C	CSF-30C
UT-4C	✓	✓	✓	✓	✓	✓
BC-16F	✓					
BC-18F		✓				
BC-19F			✓			
BC-20F				✓		
BC-25F					✓	
BC-30F						✓
IN-16F	✓					
IN-18F		✓				
IN-19F			✓			
IN-20F				✓		
IN-25F					✓	
IN-30F						✓
CE-12	✓	✓	✓	✓	✓	✓
CEB-5	✓	✓	✓	✓	✓	✓

"F" SERIES TOOL BOX

TOOL WITH PRESSURE COMPENSATION SYSTEM



CODE	F SERIES SET COMPOSITION
UT-C	N°1 SINGLE TOOL
CE	N°1 SPECIAL HEXAGONAL KEY
CEB	N°1 "T" BETA HEXAGONAL KEY
BC-F	N°1 CENTERING BUSH FOR EACH SIZE
IN-F	N°1 CUTTER FOR EACH SIZE

Order example: CSF-10-12C

CODE	CSF-10-11C	CSF-10-11,5C	CSF-10-12C	CSF-10-14C	CSF-11-11,5C	CSF-11-12C	CSF-11-14C	CSF-11,5-12C	CSF-11,5-14C	CSF-12-14C
UT-3C	✓	✓	✓	✓	✓	✓	✓	✓	✓	✓
BC-10F	✓	✓	✓	✓						
BC-11F	✓				✓	✓	✓			
BC-11,5F		✓			✓			✓	✓	
BC-12F			✓			✓		✓		✓
BC-14F				✓			✓		✓	✓
IN-10F	✓	✓	✓	✓						
IN-11F	✓				✓	✓	✓			
IN-11,5F		✓			✓			✓	✓	
IN-12F			✓			✓		✓		✓
IN-14F				✓			✓		✓	✓
CE-8	✓	✓	✓	✓	✓	✓	✓	✓	✓	✓
CEB-3	✓	✓	✓	✓	✓	✓	✓	✓	✓	✓

TOOL WITH PRESSURE COMPENSATION SYSTEM

CODE	F SERIES SET COMPOSITION
UT-C	N°1 SINGLE TOOL
CE	N°1 SPECIAL HEXAGONAL KEY
CEB	N°1 "T" BETA HEXAGONAL KEY
BC-F	N°1 CENTERING BUSH FOR EACH SIZE
IN-F	N°1 CUTTER FOR EACH SIZE

Order example: CSF-16-20C



CODE	CSF-10-12-14C	CSF-16-20C	CSF-16-25C	CSF-20-25C	CSF-16-20-25C
UT-3C	✓				
UT-4C		✓	✓	✓	✓
BC-10F	✓				
BC-12F	✓				
BC-14F	✓				
BC-16F		✓	✓		✓
BC-20F		✓		✓	✓
BC-25F			✓	✓	✓
IN-10F	✓				
IN-12F	✓				
IN-14F	✓				
IN-16F		✓	✓		✓
IN-20F		✓		✓	✓
IN-25F			✓	✓	✓
CE-8	✓				
CE-12		✓	✓	✓	✓
CEB-3	✓				
CEB-5		✓	✓	✓	✓

CONTROL GAUGE FOR RETAINING GROOVE

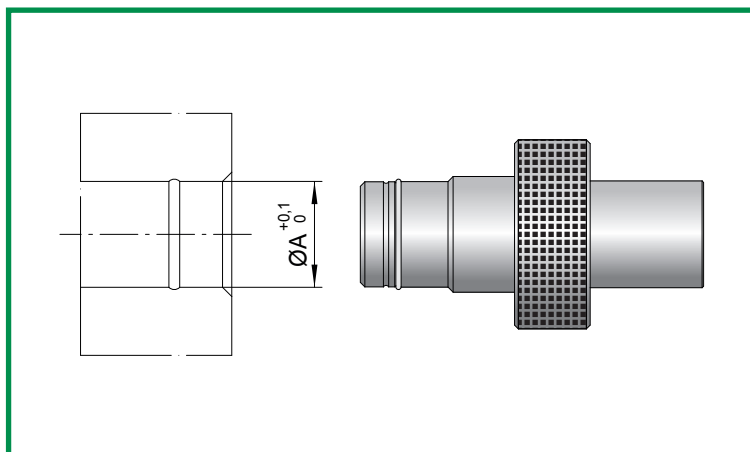

CODE	ØA
CST-6F	6
CST-8F	8
CST-10F	10
CST-12F	12
CST-14F	14

CODE	ØA
CST-6	6,5
CST-8	8,5
CST-10	10,5
CST-12	12,5
CST-14	14,5

REALIZATION OF THE SEAT:

Thanks to the proper gauge it is possible to check the hole dimension and the retaining groove.

O-RING COMPOUND

O-ring maximum working temperature changes with the type of fluid.

ERMANNO BALZI cooling components are equipped with FKM O-rings suitable to work with pressurized water or oil up to 150 °C.

In case of applications requiring the circulation of fluids such as steam, pressurized water or oil at high temperature we suggest to apply O-ring made in special FKM compounds properly developed to guarantee better performance.

- O-ring for steam or pressurized water suitable for working temperature up to 190 – 200°C and peak temperature of 220°C.
- O-ring for diathermic oil suitable for working temperature up to 200 – 220°C and peak temperature of 250 – 270°C.

DIAM.	O-RING STEAM (ST)	O-RING OIL (HO)
6	✓	✓
6,5	✓	
8	✓	✓
8,5	✓	
10	✓	✓
11	✓	
11,5	✓	✓
12	✓	✓
14	✓	
15	✓	
16	✓	✓
19	✓	✓
20	✓	✓
25	✓	✓

Order example with steam o-ring: TR-8FST

Order example with oil o-ring: TR-8FHO