

DOG LIFTER - DG

ES Patin Vertical - DG DE Vertikal Schrägschieber - DG
 IT Pattino Automatico - DG PT Patim Automatico - DG FR Cale Automatique - DG

● Cad Insertion Point

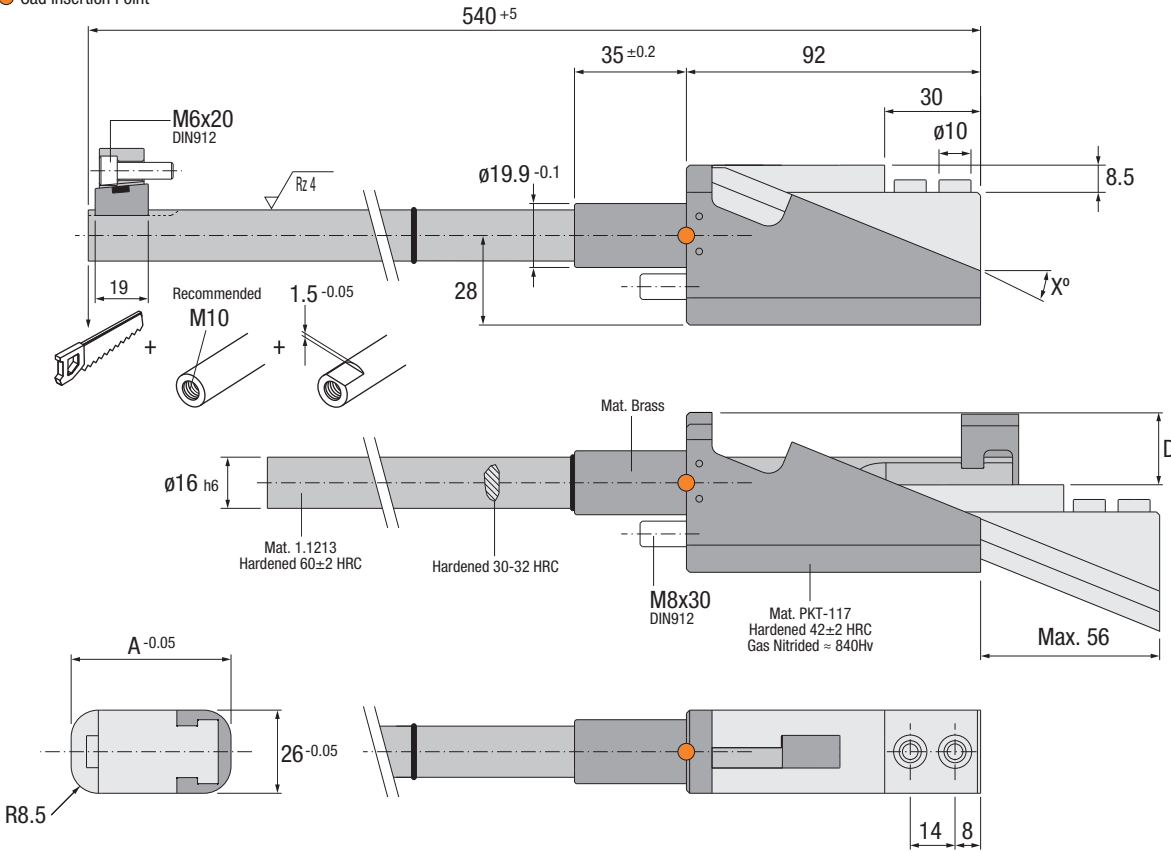

DG

UNDERCUTS



Patented

IMPORTANT !

Special angles available upon request, please contact: technical@cumsa.com
 Ángulos especiales disponibles bajo demanda, por favor, contactar: technical@cumsa.com
 Sonderwinkeln auf Anfrage, bitte kontaktieren Sie: technical@cumsa.com
 Angoli speciali disponibili su richiesta, nel caso, scrivete a: technical@cumsa.com
 Ángulos especiales por encomenda, por favor contactar: technical@cumsa.com
 Pour les angles spécifiques, merci de contacter: technical@cumsa.com

Ref.	A	D	T	X
DG.264592	45	16	M6x30	16
DG.265092	50	22	M6x30	22
DG.265592	55	26	M6x35	26

Installation Guidelines

Consejos de Instalación · Richtlinien zur Installation · Consigli di Installazione · Instruções de Instalação · Mode d'Installation

