



## REFERENCE INSERT

ES Inserto Referencia DE Recyclingeinsätze  
IT Inserti di Riciclaggio PT Indicadores de Reciclagem FR Pion de Recyclage

● Cad Insertion Point

# IR

TRACEABILITY

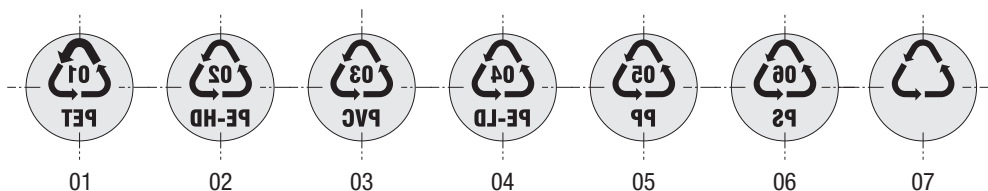
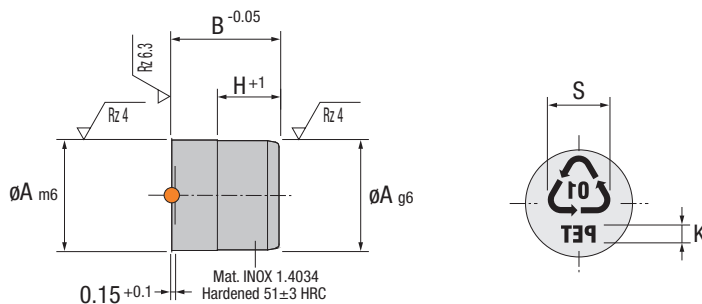

Ref.	A	B	E	H	K	S
IR.1012..	10	12	8	7	1.5	5.6
IR.1212..	12	12	10	7	1.8	6.8
IR.1616..	16	16	12	9	2.4	9
IR.2016..	20	16	16	9	3.2	11.5

**IMPORTANT** !

Indicate the model after the reference.  
Indicar el modelo después de la referencia.  
Wählen Sie den Typ entsprechend der Referenz.  
Indicare il modello dopo il codice.  
Indicar o modelo depois da referência.  
Indiquer le sigle après la référence.

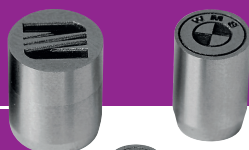

## MARK INSERT

ES Inserto Marca DE Einsätze für Symbole  
IT Inserto Simbolo PT Posição de Marcas FR Insert de Marquage

# IM

TRACEABILITY

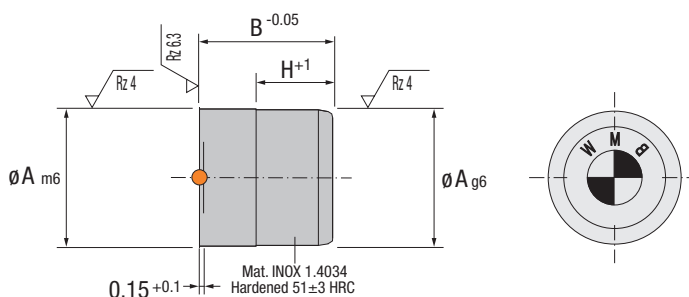

Ref.	Blank Ref.	A	B	E	H
IM.041000	IM.041000-BLANK	4	10	2	6
IM.051000	IM.051000-BLANK	5	10	3	6
IM.061000	IM.061000-BLANK	6	10	4	6
IM.081200	IM.081200-BLANK	8	12	6	7
IM.101200	IM.101200-BLANK	10	12	8	7
IM.121200	IM.121200-BLANK	12	12	10	7
IM.161600	IM.161600-BLANK	16	16	12	9
IM.201600	IM.201600-BLANK	20	16	16	9

**IMPORTANT** !

Send DXF file with your design.  
Envíenos un archivo DXF con su diseño.  
Senden Sie als DXF File.  
Inviare un file DXF con il disegno dell'incisione richiesta.  
Envie-nos um ficheiro em DXF com o seu desenho.  
Envoyez nous le fichier DXF du dessin.

### Installation Guidelines

Consejos de Instalación · Richtlinien zur Installation · Consigli di Installazione  
Instruções de Instalação · Mode d'Installation

