

REMOTE DATE STAMP

ES Fechador Remoto DE Ferngesteuerter Datumssteller
IT Datario Remoto PT Datador Remoto FR Commande à Distance

● Cad Insertion Point

FR

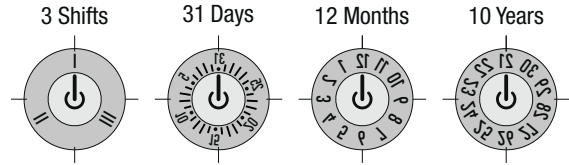
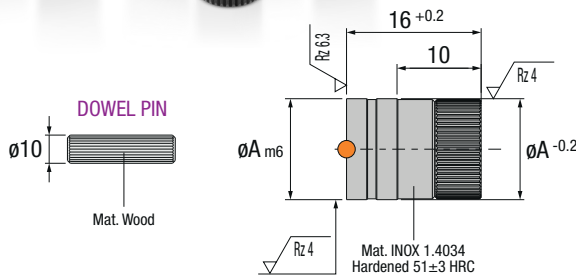

TRACEABILITY



Patented

Max. 150°C

	3 Shifts	31 Days	12 Months	10 Years	A
Raised lettering	FR.08HR03	FR.08HR31	FR.08HR12	FR.08HR10-..	8
	FR.12HR03	FR.12HR31	FR.12HR12	FR.12HR10-..	12
Recessed lettering	FR.08LR03	FR.08LR31	FR.08LR12	FR.08LR10-..	8
	FR.12LR03	FR.12LR31	FR.12LR12	FR.12LR10-..	12

IMPORTANT

Indicate the year after the reference.
Indicar el año después de la referencia.
Geben Sie das Jahr nach dem Verweis an.
Indicare l'anno dopo il codice.
Indicar o ano depois da referência.
Indiquer l'année après la référence.

CF

REMOTE DATE STAMP SHAFT SET

ES Conjunto Varilla para Fechador Remoto DE Fernbedienbares Wellenset IT Set Asta per Datario Remoto
PT Conjunto de Transmissão para Datador Remoto FR Jeu de Tige pour Changement d'Information

● Cad Insertion Point

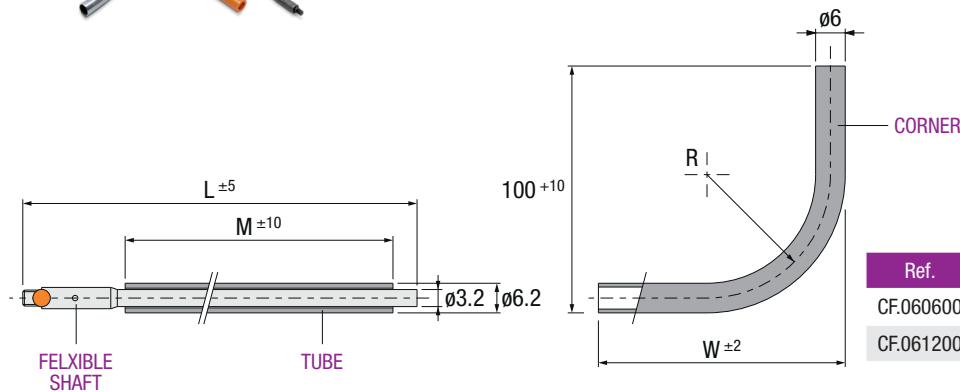

Ref.	L	M	R	S	T	U	W
CF.060600	600	500	25	30	40	45	40
CF.061200	1200	1100	40	50	60	60	60

TRACEABILITY



MN

REMOTE COMMAND

ES Mando Remoto DE Fernbedienbar
IT Comando Remoto PT Comando Remoto FR commande à Distance

● Cad Insertion Point

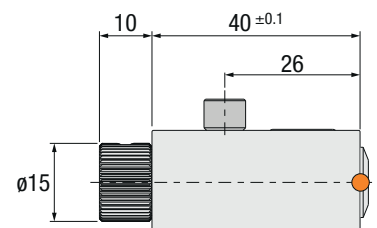
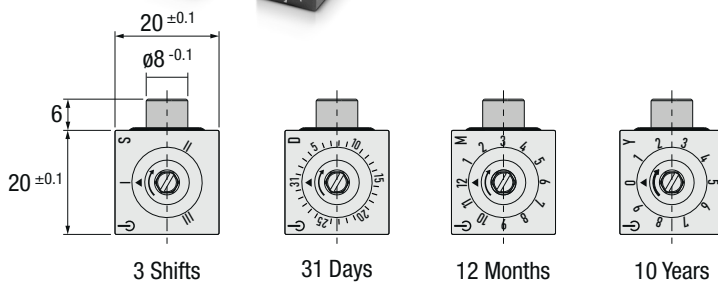

Ref.	# of Positions
MN.202003	3 (Shifts)
MN.202010	10 (Years)
MN.202012	12 (Months)
MN.202031	31 (Days)

IMPORTANT

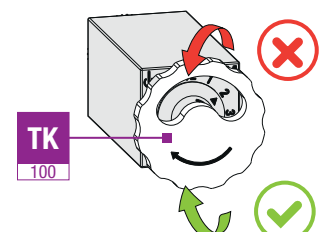

INSTALLATION GUIDELINES

ES Consejos de Instalación DE Richtlinien zur Installation
 IT Consigli di Installazione PT Instruções de Instalação FR Mode d'Installation

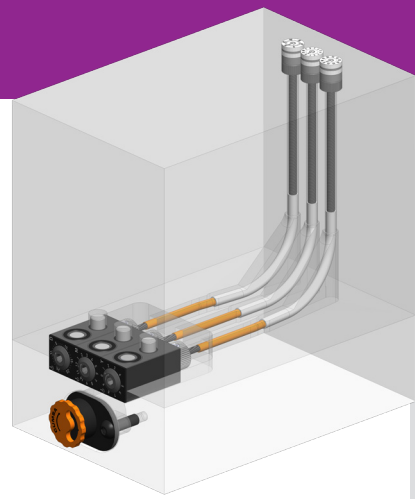

FR

TRACEABILITY



Patented

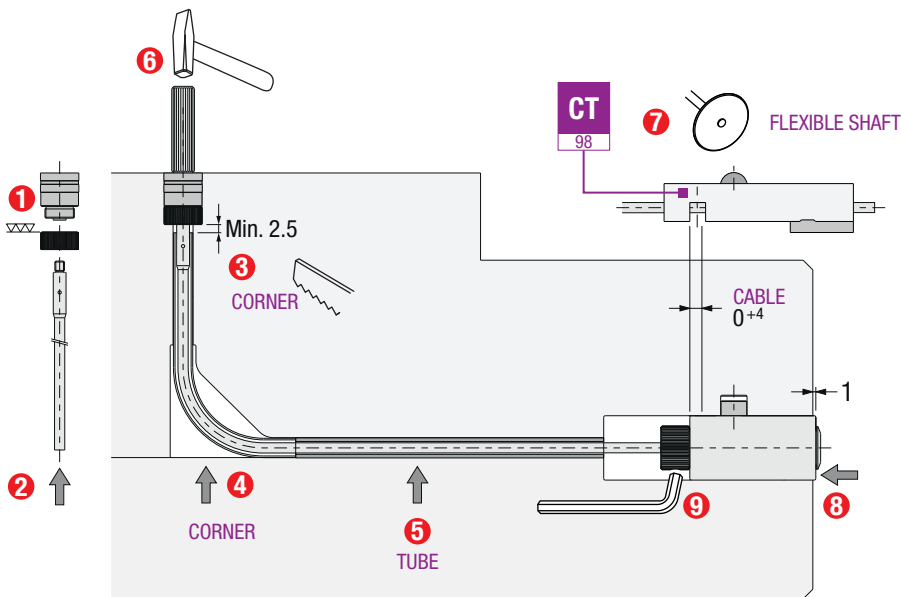
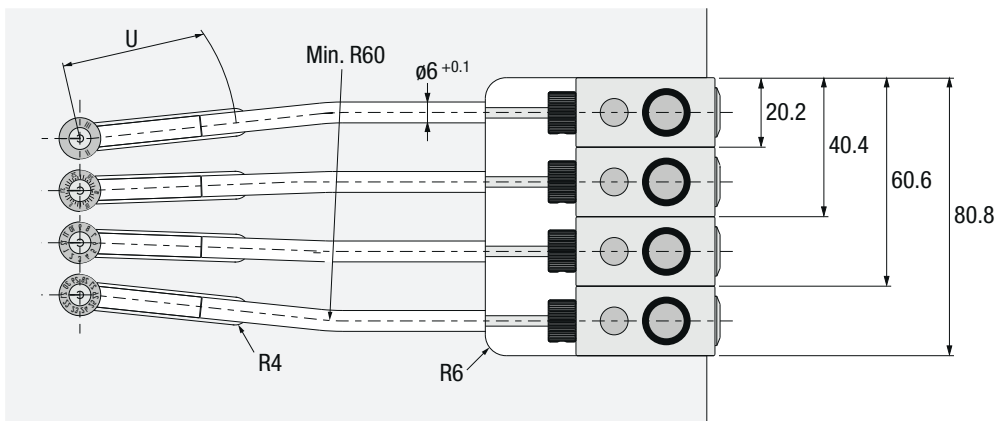
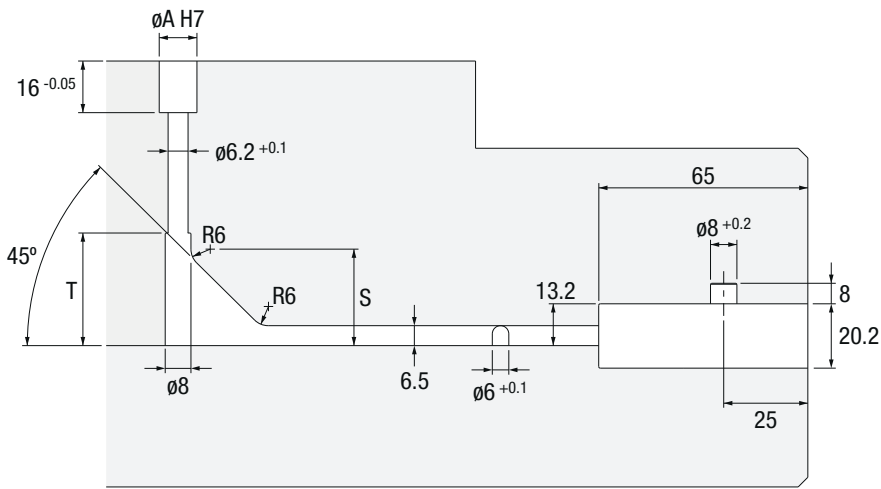

10 **MN** 98 **FR** 98

Synchronize

IMPORTANT