

● Cad Insertion Point

PF

UNDERCUTS



Patented

Max. 150°C

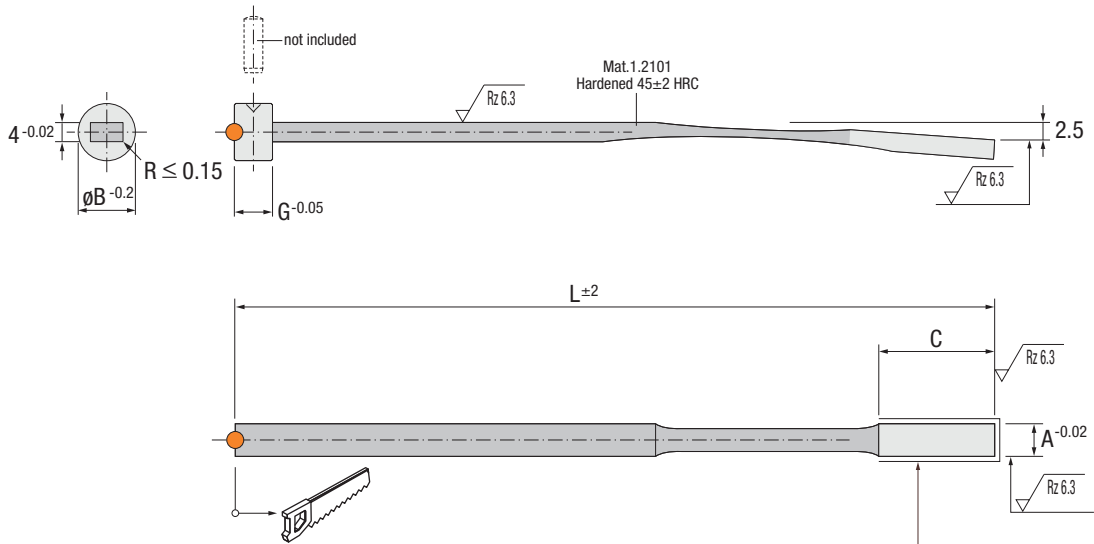

Ref.	A	B	C	G	H	L	M	N	P	R	Balinit C [®]	Hardened
PF.044150	4	8	24	6	6	150	12	14	0.8	30	●	52±2 HRC
PF.054150	5	8	24	6	6.5	150	12	14	0.8	30	●	52±2 HRC
PF.064200	6	12	30	8	7.5	200	18	20	1	36	●	52±2 HRC
PF.0642WB	6	12	30	8	7.5	200	18	20	1	36	-	56±2 HRC
PF.084200	8	14	30	8	9	200	18	20	1	36	●	52±2 HRC
PF.0842WB	8	14	30	8	9	200	18	20	1	36	-	56±2 HRC
PF.104200	10	16	30	8	11	200	18	20	1	36	●	52±2 HRC
PF.1042WB	10	16	30	8	11	200	18	20	1	36	-	56±2 HRC
PF.124200	12	18	30	8	13	200	18	20	1	36	●	52±2 HRC
PF.1242WB	12	18	30	8	13	200	18	20	1	36	-	56±2 HRC

Installation Guidelines

Consejos de Instalación · Richtlinien zur Installation · Consigli di Installazione · Instruções de Instalação · Mode d'Installation

