

XTRA SPRUNG CORE

ES Pinza Extra DE Xtra Federnder Auswerfer
IT Pinza Piana Extra PT Pinça Plana Extra FR Éjecteur de Forme Extra

● Cad Insertion Point

PX

UNDERCUTS



Patented

Max. 150°C

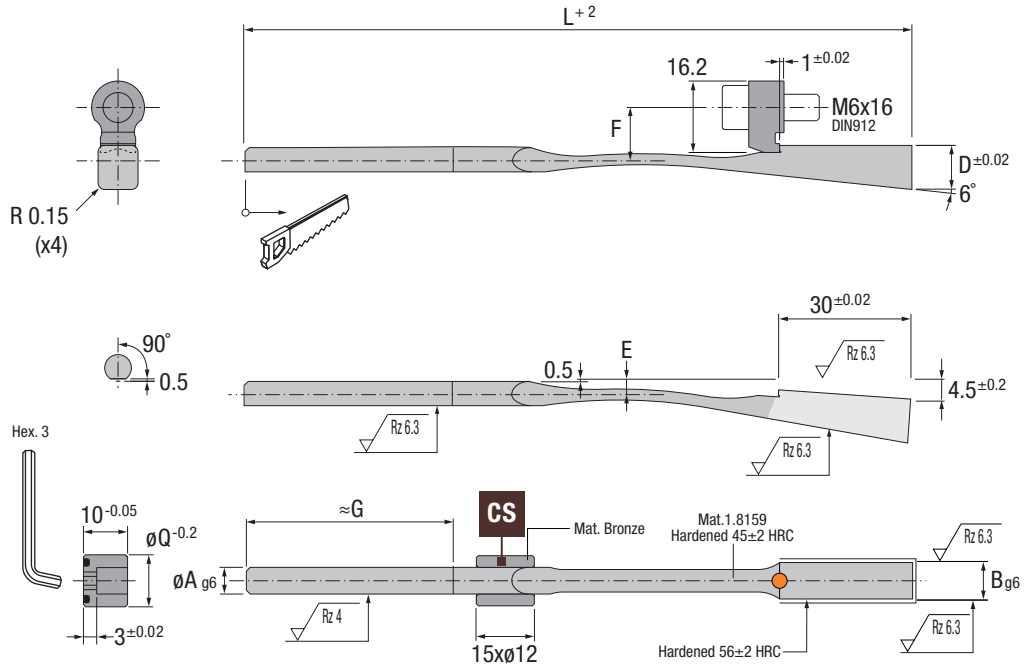

Ref.	A	B	D	E	F	L=175		L=250		L=325		N	Q
						≈G	CS	≈G	CS	≈G	CS		
PX.060630-...	6	6.2	10	3.5	12.5	60	-	80	●	80	●	2.5	12
PX.060830-...	6	8.2	10	3.5	12.5	60	-	80	●	80	●	2.5	12
PX.081030-...	8	10.2	11.2	4.5	13.5	60	-	80	●	80	●	3.5	14
PX.081230-...	8	12.2	11.2	4.5	13.5	60	-	80	●	80	●	3.5	14

IMPORTANT
Indicate the desired **L** dimension after the reference.
Indicar al final de la referencia, la cota **L** deseada.
Gewünschte Länge (**L**) angeben.
Indicare la quota **L** desiderata alla fine del codice.
Indique o dimensão **L** desejada depois da referência.
Indiquer la cote **L** désirée per compléter le référence.

Installation Guidelines

Consejos de Instalación · Richtlinien zur Installation · Consigli di Installazione · Instruções de Instalação · Mode d'Installation

