

UC



SLIDES



Patented

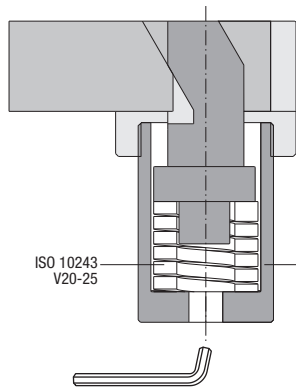

ISO 10243 V20-25 Mat. 1.2344 Hardened 53±2 HRC

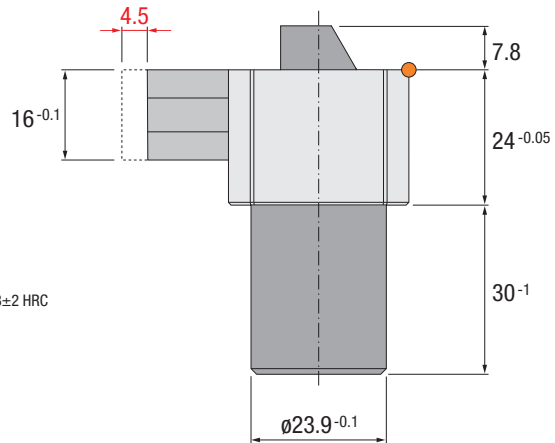

Ref.  
UC.325445

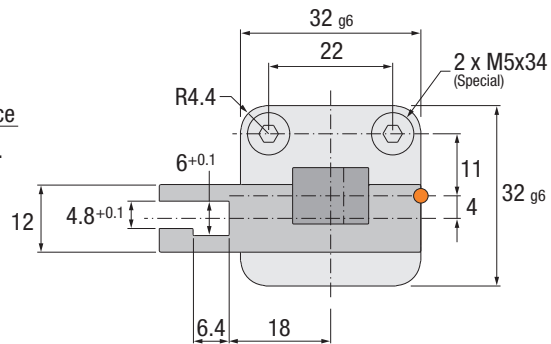
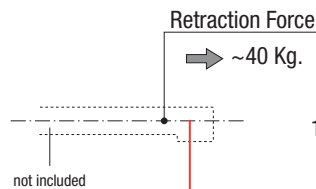

**IMPORTANT !**  
 Option for machining keyway.  
 Posibilidad de mecanizado antigiro.  
 Möglichkeit zur Herstellung einer Aussparung.  
 Possibilità di lavorazione antigiro.  
 Possibilidade de maquinar anti-rotação.  
 Possibilitè d'indexer la broche.

**IMPORTANT !**  
 Standard stroke of 4.5mm.  
 Recorrido estándar de 4.5mm.  
 Standard Hub 4.5mm.  
 Corsa del asta 4.5mm.  
 Curso standard de 4.5mm.  
 Course standard de 4.5mm.

Installation Guidelines

Consejos de Instalación · Richtlinien zur Installation · Consigli di Installazione · Instruções de Instalação · Mode d'Installation

