

UNDERCUT UNIT

ES Corredera para Negativos DE Verdeckte Schieber
 IT Carrello per Sottosquadra PT Elemento Móvel Interior FR Chariot Intérieur

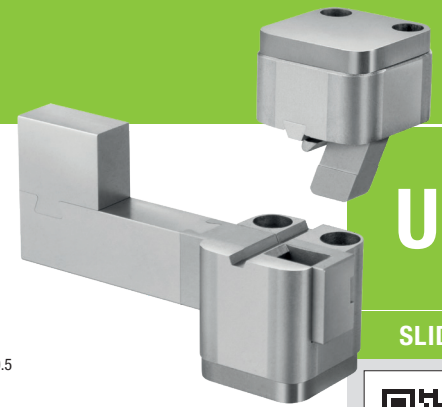

UU

SLIDES



Patented

● Cad Insertion Point

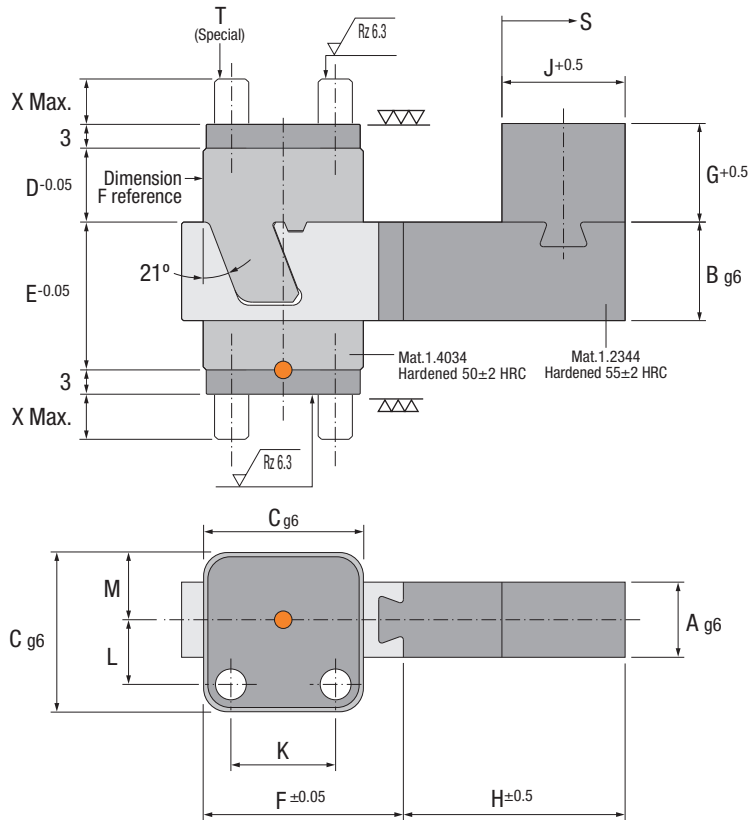

Ref.	A	B	C	D	E	F	G	H	J	K	L	M	R	S	T	X
UU.081220	8.2	12	20	10	18	24.5	12	32	16	12.5	8.25	8	3.75	3	M4	6.2
UU.121626	12.2	16	26	12	24	32.5	16	36	20	17	10.5	11	4.5	4	M5	7.2
UU.162032	16.2	20	32	16	30	41	20	50	25	22	13	14	5	5	M6	9.2

Installation Guidelines

Consejos de Instalación · Richtlinien zur Installation · Consigli di Installazione · Instruções de Instalação · Mode d'Installation

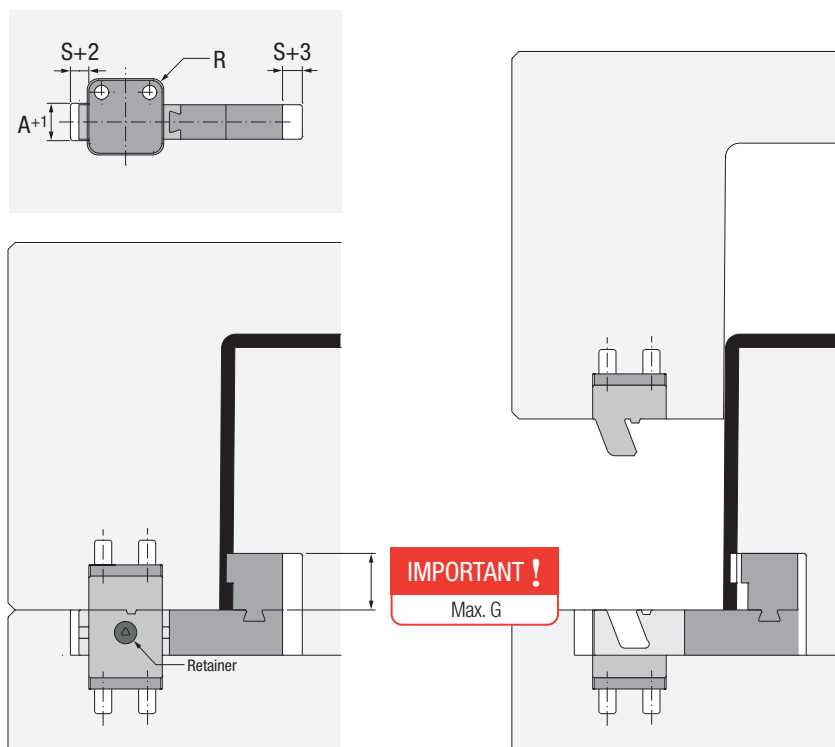

IMPORTANT !
Max. G